

DL2RT+EXTRA A-C(OPTION B)

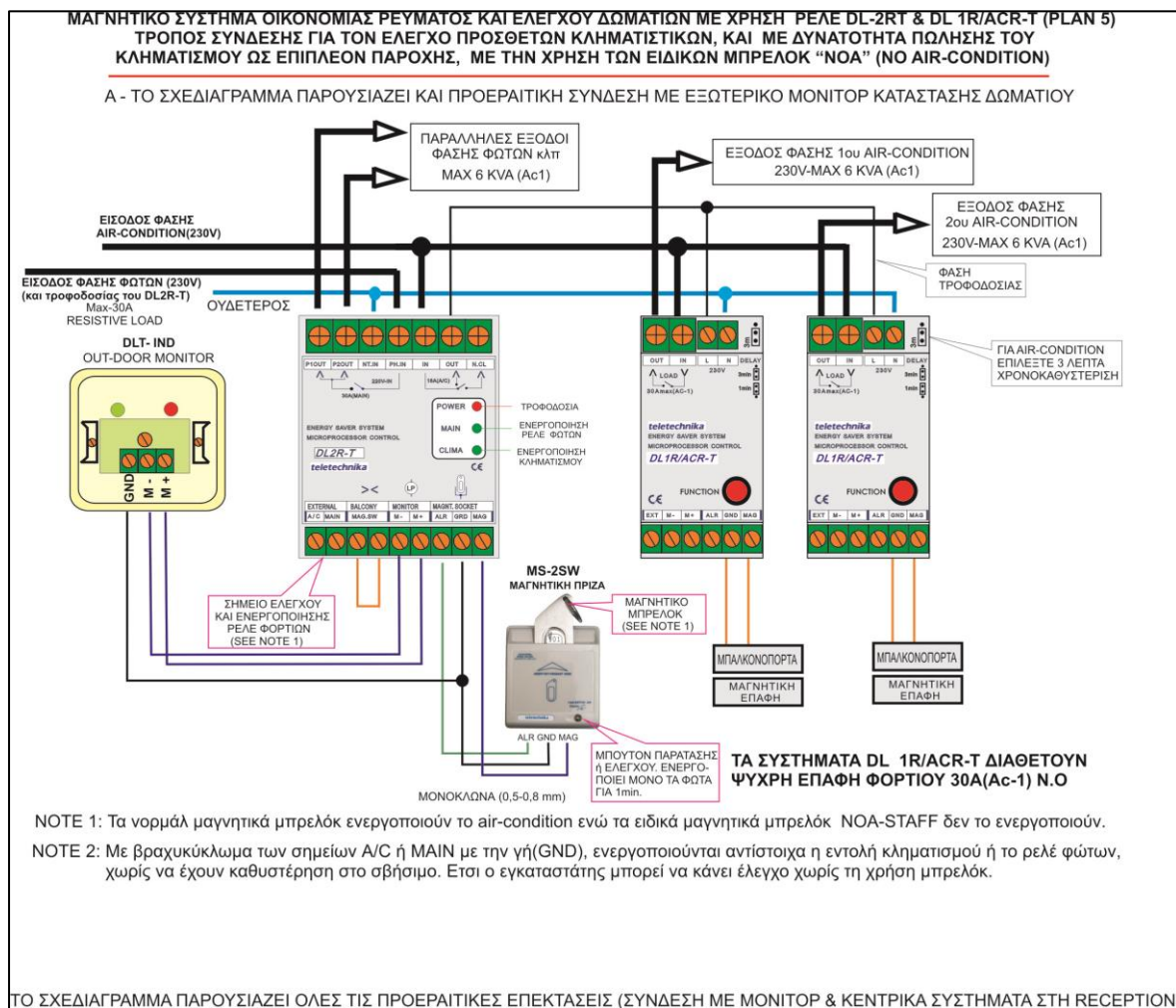

DL2R-T CONECTION-COMLETE-GR

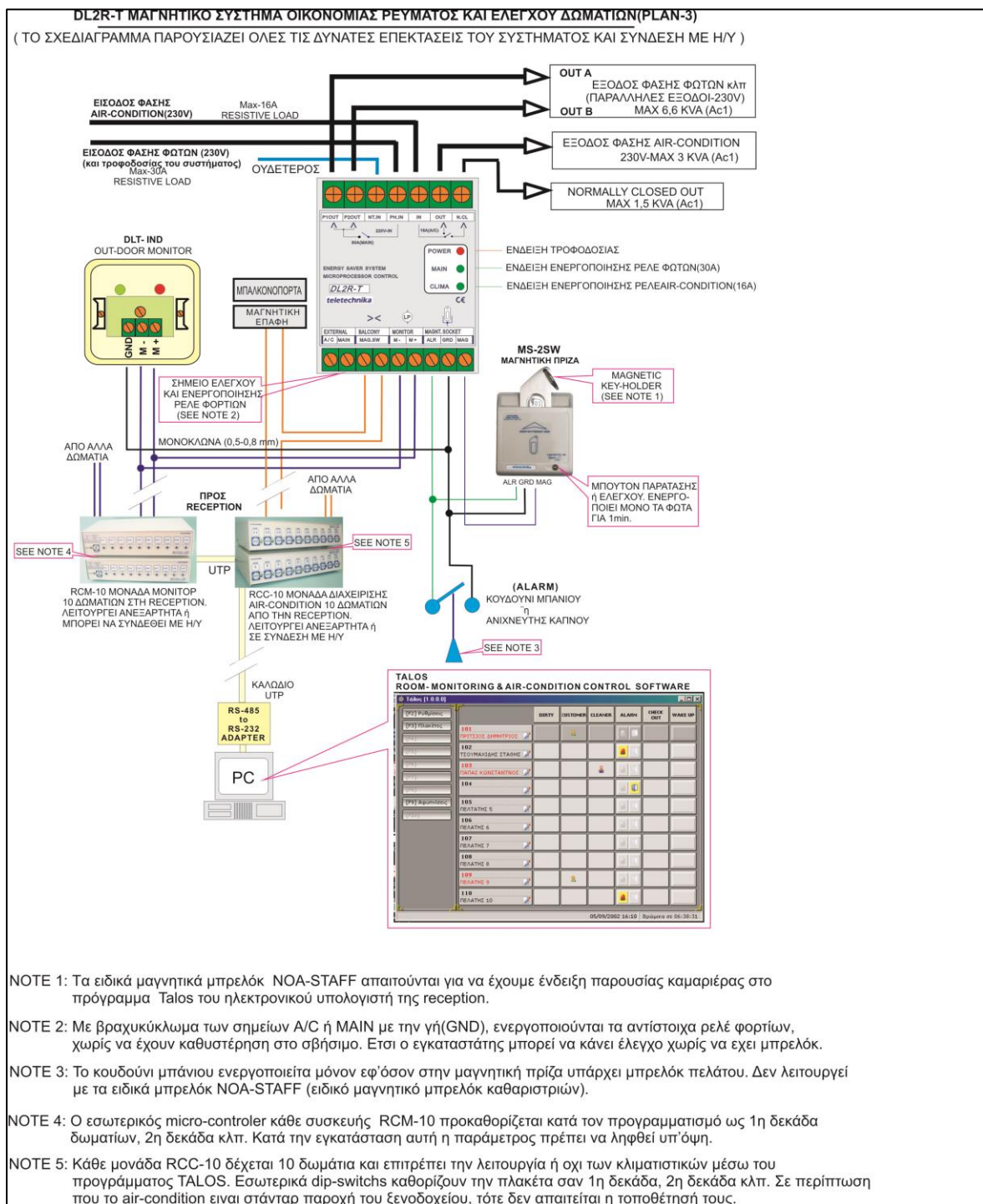

DL2R-T CONNECTION-withoutPC-GR

